

Vertical Float Type Level Switch

Model : SMC-7 Series



SeoJin Instech Co., Ltd.

www.seojin.biz

SMC-7 Series

Vertical Float Type Level Switch



Features

- Can be used for vessel under high pressure and temperature
- Designed to ASME B31.1
- Weather proof
- Explosion-proof & Frame-proof
- Unique and reliable : Snap acting switch mechanism
- Vibration resistant - eliminates fake trips by special spring
- A wide variety of chambers can be used.
- Multiple switches can be assembled in a unit for economical purpose.
- Weld procedures approved to KEPIC MQ and ASME IX
- Material certification to ASTM, ASME, JIS, KS Standards
- Qualified to IEEE 323-2003, and IEEE344-2004
- Applicable to hermetical seal type snap action switch

Operation

The electric contact switch operates as per the principle of magnetism, and the electric contact switch is normally relay-off " position because of tension spring. There is magnetic steel on the edge of Float's Rod, and this magnetic steel sticks to magnet installed inside the housing when the level goes up as Fig. 1. At this time, electric contact switch turns on because the switch designed to " relay-on " when the magnet sticks to magnetic steel of the Float s Rod. When the level goes down such as Fig. 2, on the contrary, the Float goes down and accordingly the magnetic steel on the Float s edge goes down. Therefore, the magnetic steel detaches from the magnet and the switch is returning to " relay-off " position due to tension spring.

SMC-7 Series
Vertical Float Type Level Switch

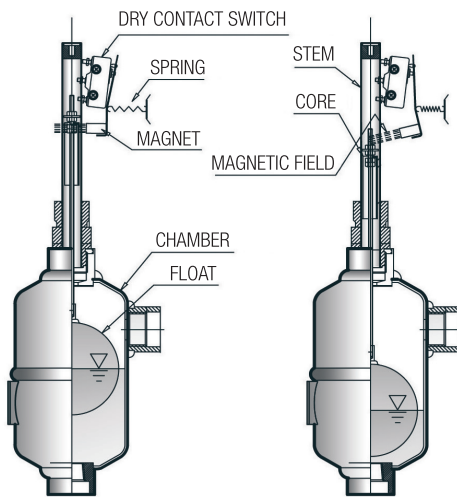

Fig.1. Switch Connected

Fig.2. Switch Released



Introduction

This product is a unique level switch as a critical Process Instrument covering high pressure and high temperature. Chamber material for this product is not only carbon steel, but also many variety steel materials including 316LSS and 304SS.

This product has been produced for suitable in water and boiler control process, meeting various industrial standards and requirements to solve erroneous causes that have occurred in conventional industrial fields.

The customizing for this product is possible for specific operational condition and anti-corrosion. Please contact our sales staff if you have any special design for this product.

Approvals

ATEX (ATmosphere EXposables)
 Approval INERIS11ATEX0003X
 Explosion proof Ex d IIC T6
 (-20°C < AMB < 60°C)

KOSHA (The Korea Occupational Safety and Health Agency)- Approval Explosion proof Ex d IIC T6
 (-20°C ≤ AMB ≤ 60°C)
 General Area, Weather proof type IP67

TÜV- Approval
 CE Certificate
 EN-61010-1-2001

KTL (Korea Testing Laboratory)- Tested to verify the requirements of Nuclear Power Plant Quality Standards.
 IEC Pub.60068 Basic Environmental Testing Procedures

KEPIC Certificate of Registration
 MN-125

ISO 9001:2008 / ISO 14000/2004

Seojin Instech has been assessed and approved by CREBIZ QM against ISO 9001 : 2008 for the design, development, assembly and recalibration of precision instruments and systems for the measurement and indication of electrical signals and, level, flow and water/ steam systems.

Quality Assurance

With over 35 year worldwide experience in the thermal power plant, nuclear power plant and petro-chemical industries, Seojin Instech is able to accommodate testing, surveying and documentation requirements as specified at the time of order. Inspection by customers or nominated inspection agencies can be arranged.

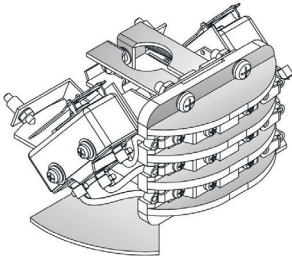
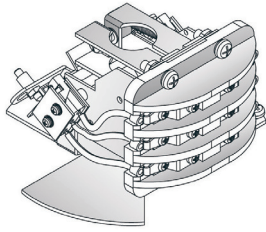

WIRING DIAGRAM

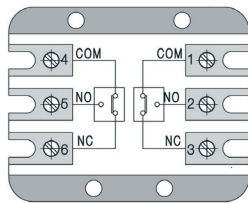

■ Where the product is produced with the cooling fin, the maximum allowable temperature of pressurized liquid process is up to 550°C. Except that the specific gravity shall be beyond 0.6.

Technical Specifications

Least Specific Gravity of Process : 0.6

Snap Acting Switch Assembly

- Switching Type : Snap Acting Switch, Dry Contact Type
- Contact(Output) : 1 SPDT, 2 SPDT, 1 DPDT
- Accuracy : ±1mm,
- Maximum Applicable Temperature : 400°C
- Body Material : 304SS
- Terminal Material : Pure Ceramic

Chamber

- Made According to ASME B31.1, KEPIC MGE.
- Material : CS(Std.), 304SS, 316SS, etc.

Float

- Material : 316SS(Std.), Monel
- Float Specific Gravity : Minimum 0.4
- Size : SMC-73 : OD 90mm,
SMC-75 : OD 110mm,
- Maximum Temperature of Process Liquid : 550°C
- Maximum Pressure of Process :
SMC-73 : 46Bar, SMC-75 : 70Bar
- Hydrostatic Test Pressure :
SMC-73 : 70Bar, SMC-75 : 150Bar

Switch Assembly

► **Snap Acting Switch Assembly Chart**

Type (Model)	SM1S	SM1D	SM2S	SM2D	SM3S	SM3D	SM4S	SM4D	SM5S	SM5D
Action	SPDT / DPDT		SPDT / DPDT		SPDT / DPDT		SPDT / DPDT		SPDT / DPDT	
Max. Process Liquid Temp. ^(Note1)	120°C		450°C		450°C		550°C		550°C	
Micro Switch Operating Temperature Range	- 25 ~ 80°C		- 54 ~ 200°C		- 54 ~ 204°C		- 65 ~ 260°C		- 65 ~ 400°C	
Voltage & Current	250V AC 10A		250V AC 5A		250V AC 15A		115V AC 1A		250V AC 1A	
	125V DC 0.6A		125V DC 0.5A		125V DC 1A		28V DC 3A		30V DC 1A	
Remark							Hermetical seal			
Max. Process Temp. When Applied (3ea) A chamber Equipped With Cooling Fin. (5ea)			350°C		350°C		450°C		450°C	
			450°C		450°C		550°C		550°C	

Note (1) It may only apply into the ambient temperature less than 60°C

Switch Enclosure

Type (Model)	Material		Specification for Protection	Dimension	Conduit entries
	Cover	Base			
A	Drawn CS	Al Alloy	NEMA 4x	Ø117 x 218H	3/4" PF
			IP65		
B	Al Alloy	Al Alloy	NEMA 4x / IP67	Ø150 x 255H	3/4" PF
			Ex d IIC T6		

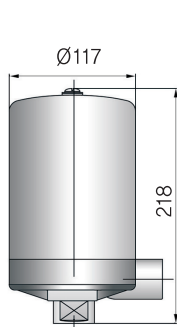

TYPE A

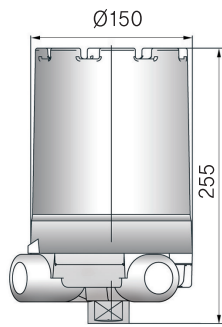

TYPE B



Switch Action Indicator

The product is designed either as a model of the extremely lowest power consumption, or only activated when it is contacted in the switch. Either may be it not only operated by a separated power source in the site but also by an independent power source (dry cell).

It has been proved against high-thermal impact by structuring with stainless steel body, laminating with polycarbonate resin combined with radiation component.

Body Material : Stainless Steel, Polycarbonate

Light Source : LED

Range of Power Voltage : 5~24V DC

Ambient Temp. : -5~60°C

Continuous Running Time(at 25°C) by Battery :144hr

* 8month life time for event action condition

Protection : NEMA 4 / IP67

Installation : 1" NPT

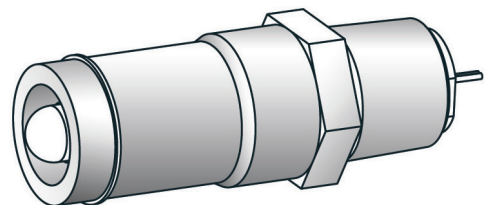

SMC-73B

4" Bottle Seal Type

Ordering Informations

Vertical Float Type Level Switch (4" Bottle Seal Type - Max. Pressure : 46Bar)

SMC - 73 B 1 A 1 A 1 A 1 A 1 A

MODEL SELECTION

B = 4" Bottle Seal Type
(Max. Temp : 450°C,
Max. Press : 46 Bar)

CHAMBER MATERIAL

1 = Carbon Steel (Std.)
2 = 304 SS
3 = 316 SS

FLOAT MATERIAL

A = 316 SS (Std.)

PROCESS CONNECTION TYPE

1 = Side-Bottom (STD.)
2 = Side-Side
3 = Side-Side (Elbow Type)
4 = Side-Side (Tee Type)
5 = Side Bottom (Cooling Fin)

PROCESS CONNECTION SIZE

A = 1" S.W(Std.) E = 300# 3/4"
B = 3/4" S.W F = 300# 1"
C = 150# 3/4 G = 600# 3/4"
D = 150# 1" H = 600# 1"

SNAP SWITCH ACTION (OUTPUT)

1 = 1 SPDT
2 = 1 DPDT (2 SPDT)

PAINTING

A = MFR Std.(Seojin Spec.)
B = etc.

DRAIN PARTS

1 = None
2 = etc.

CONDUIT CONNECTION

A = PF 3/4" (Std.)
B = PT 3/4"
C = NPT 3/4"
D = NPT1/2"
E = etc.

ENCLOSURE

1 = Weather Proof (Std., IP65, C.S Cover)
2 = Explosion Proof (Ex d IIC T6, IP67)
3 = ATEX (Ex d IIC T6)

PROCESS TEMP'

A = Max.120" (10A 250V/AC/0.6A 125V DC)
B = Max.230" (5A 250V AC/0.5A 125V DC)
C = Max.400" (1A 250V AC/1A 30V DC)
D = Max.230" (15A 250V AC/1A 125V DC)
E = Max.400" (1A 115V AC/3A 28V DC)
(Hermetical Seal Type)
F = Max.350" (5A 250V AC/0.5A 125V DC/Cooling Fin 3ea)
G = Max.450" (1A 250V AC/1A 30V DC/Cooling Fin 3ea)
H = Max.350" (15A 250V AC/1A 125V DC/Cooling Fin 3ea)
I = Max.450" (1A 115V AC/3A 28V DC/Cooling Fin 3ea)
(Hermetical Seal Type)

SMC-73B 4" Bottle Seal Type
SMC-73F 4" Flange Type

When placing an order, selected ordering number should be indicated on the purchase order sheet.

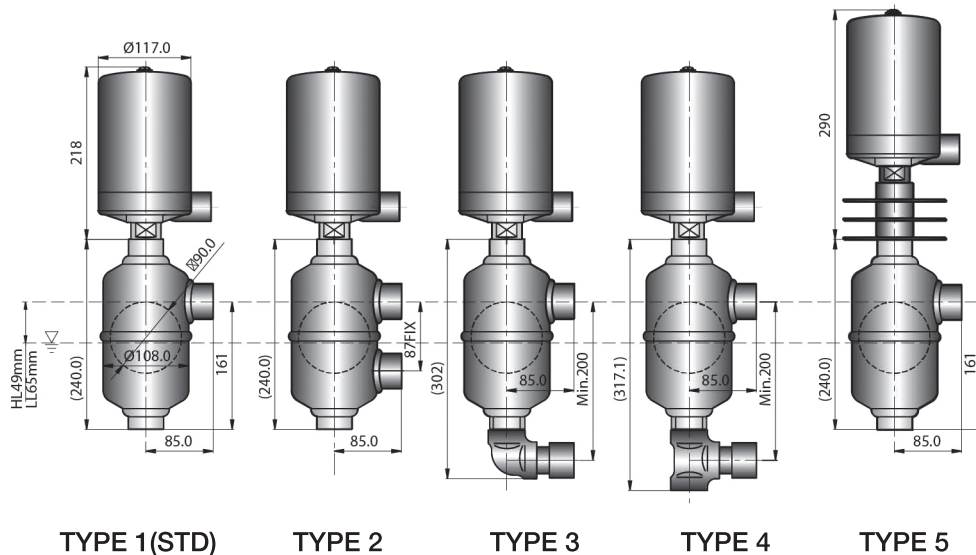

C to C of SMC-73B is fixed like the above length.

SMC-73F

4" Flange Type

Ordering Informations

Vertical Float Type Level Switch (4" Flange Type)

SMC - 73 F 1 A 1 A 1 A 1

CONDUIT CONNECTION

- 1 = PF 3/4" (Std.)
- 2 = PT 3/4"
- 3 = etc.

ENCLOSURE

- A = Weather Proof (Std., IP65, C.S Cover)
- B = Explosion Proof (Ex d IIC T6, IP67)
- C = ATEX (Ex d IIC T6)

PROCESS TEMP'(CONTACT RATING)

- 1 = Max.120° (10A 250V/AC/0.6A 125V DC)
- 2 = Max.230° (5A 250V AC/0.5A 125V DC)
- 3 = Max.400° (1A 250V AC/1A 30V DC)
- 4 = Max.230° (15A 250V AC/1A 125V DC)
- 5 = Max.400° (1A 115V AC/3A 28V DC)
(Hermetical Seal Type)
- 6 = Max.350° (5A 250V AC/0.5A 125V DC/Cooling Fin 3ea)
- 7 = Max.450° (1A 250V AC/1A 30V DC/Cooling Fin 3ea)
- 8 = Max.350° (15A 250V AC/1A 125V DC/Cooling Fin 3ea)
- 9 = Max.450° (1A 115V AC/3A 28V DC/Cooling Fin 3ea)
(Hermetical Seal Type)

SNAP SWITCH ACTION (OUTPUT)

- A = 1 SPDT
- B = 1 DPDT

SETPOINT

- 1 = 180mm (Std., External Cage of SEOJIN INSTECH)
- 2 = 150 ~ 300mm (Tank Top Mounting Length = Min. 150mm)

MOUNTING TYPE

- A = 4" 150# ANSI RF Flange(Std.)
- B = 4" 300# ANSI RF Flange
- C = 4" 600# ANSI RF Flange
- D = 4" 900# ANSI RF Flange
- E = 4" 1500# ANSI RF Flange
- F = etc.

FLOAT MATERIAL

- 1 = 316 SS (Std.)
- 2 = Monel

MODEL SELECTION

- F = 4" Flange Type
(Max. Temp: 450°C, Max.
Press:70 Bar)

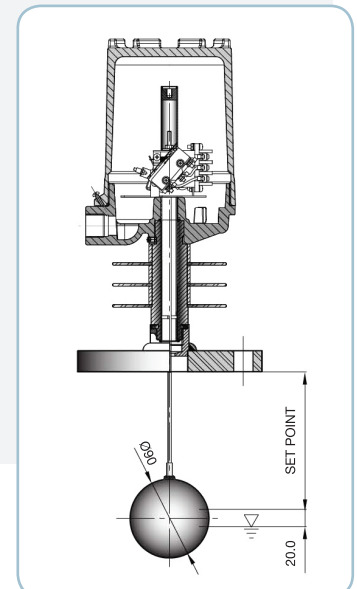
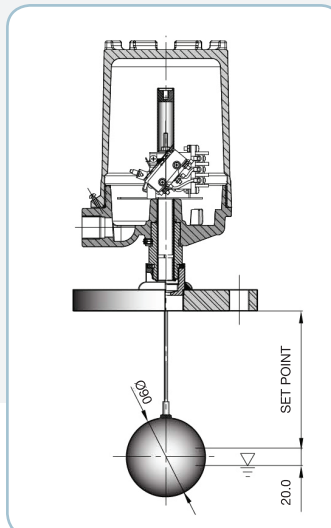

■ When placing an order, selected ordering number should be indicated on the purchase order sheet.

SMC-73CH

4" Chamber

Ordering Informations

Vertical Float Type Level Switch (Chamber)

SMC - 73CH A 1 A 1 A 1 D 1 A

TYPE OF CHAMBER

A = Side-Side
B = Side-Bottom
C = etc.

CHAMBER MATERIAL

1 = Carbon Steel (Std.)
2 = 304 SS
3 = 316 SS
4 = Carbon Steel with Teflon Coating
5 = etc.

PROCESS CONNECTION TYPE

A = Socket Welding Type (Std.)
B = Flange Type

PROCESS CONNECTION SIZE

1 = 1" (Std.)
2 = 3/4"
3 = 1-1/2"
4 = 2"
5 = etc.

TEST FOR WELDING

A = Hydro Test Only
B = PT Test + Hydro Test
C = etc.

PAINTING

1 = MFR Std. (Seojin Spec.)
2 = etc.

DRAIN PARTS (Side -Side Type Only)

A = PT 1/2" With Plug
B = PT 1/2" With Globe Valve
C = None
D = NPT 1/2" With Plug (Std.)
E = NPT 1/2" With Globe Valve
F = etc.

LENGTH (C TO C)

1 = 0 ~ 500mm
2 = 0 ~ 1,000mm
3 = 0 ~ 1,500mm
4 = 0 ~ 2,000mm
5 = etc.

TOP MOUNTING SIZE

A = 4" 150# ANSI RF Flange (Std.)
B = 4" 300# ANSI RF Flange
C = 4" 600# ANSI RF Flange
D = 4" 900# ANSI RF Flange
E = 4" 1500# ANSI RF Flange
F = etc.

SMC-73CH 4" Chamber
SMC-75B 5" Bottle Seal Type

■ When placing an order, selected ordering number should be indicated on the purchase order sheet.

SIDE-BOTTOM (SW)

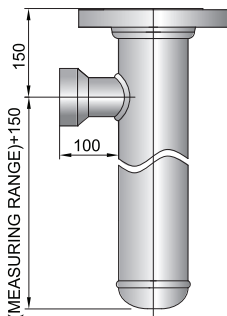

SIDE-BOTTOM (FLANGE)

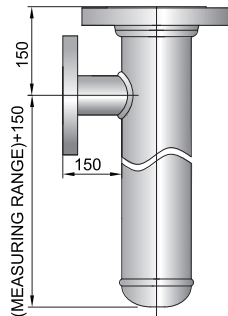

SIDE-SIDE (SW)

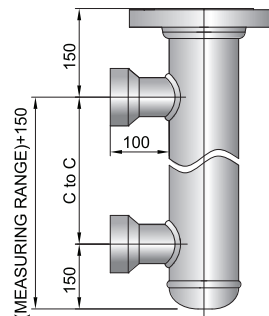

SIDE-SIDE (FLANGE)

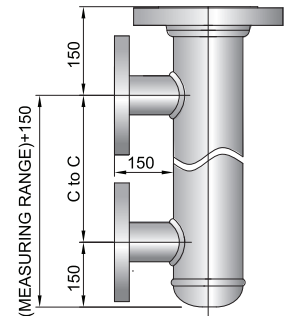

SMC-75B

5" Bottle Seal Type

Ordering Informations

Vertical Float Type Level Switch (5" Bottle Seal Type - Max. Pressure : 70Bar)

SMC - 75 B 1 A 1 A 1 A 1 A 1 A

MODEL SELECTION

B = 5" Bottle Seal Type
(Max. Temp : 550°C,
Max. Press : 70 Bar)

CHAMBER MATERIAL

1 = Carbon Steel (Std.)
2 = 304 SS
3 = 316 SS
4 = etc.

FLOAT MATERIAL

A = 316 SS (Std.)
B = Monel

PROCESS CONNECTION TYPE

1 = Side-Bottom (Std.)
2 = Side-Side
3 = Side-Bottom (Cooling Fin3)
4 = Side-Bottom (Cooling Fin5)
5 = Side Bottom (Low-density)

PROCESS CONNECTION SIZE

A = 1" S.W (Std.) E = 300# 3/4"
B = 3/4" S.W F = 300# 1"
C = 150# 3/4 G = 600# 3/4"
D = 150# 1" H = 600# 1"

SNAP SWITCH ACTION (OUTPUT)

1 = 1 SPDT
2 = 1 DPDT (2 SPDT)

PAINTING

A = MFR Std. (Seojin Spec.)
B = etc.

DRAIN PARTS

1 = None
2 = etc.

CONDUIT CONNECTION

A = PF 3/4" (Std.)
B = PT 3/4"
C = NPT 3/4"
D = NPT 1/2"
E = etc.

ENCLOSURE

1 = Weather Proof (Std., IP65, C.S Cover)
2 = Explosion Proof (Ex d IIC T6, IP67)
3 = ATEX (Ex d IIC T6)

PROCESS TEMP'

A = Max.120" (10A 250V/AC/0.6A 125V DC)
B = Max.230" (5A 250V AC/0.5A 125V DC)
C = Max.400" (1A 250V AC/1A 30V DC)
D = Max.230" (15A 250V AC/1A 125V DC)
E = Max.400" (1A 115V AC/3A 28V DC)
(Hermetical Seal Type)
F = Max.350" (5A 250V AC/0.5A 125V DC/Cooling Fin 3ea)
G = Max.450" (1A 250V AC/1A 30V DC/Cooling Fin 3ea)
H = Max.350" (15A 250V AC/1A 125V DC/Cooling Fin 3ea)
I = Max.450" (1A 115V AC/3A 28V DC/Cooling Fin 3ea)
(Hermetical Seal Type)
J = Max.450" (5A 250V AC/0.5A 125V DC/Cooling Fin 5ea)
K = Max.550" (1A 250V AC/1A 30V DC/Cooling Fin 5ea)
L = Max.450" (15A 250V AC/1A 125V DC/Cooling Fin 5ea)
M = Max.550" (1A 115V AC/3A 28V DC/Cooling Fin 5ea)
(Hermetical Seal Type)

When placing an order, selected ordering number should be indicated on the purchase order sheet.

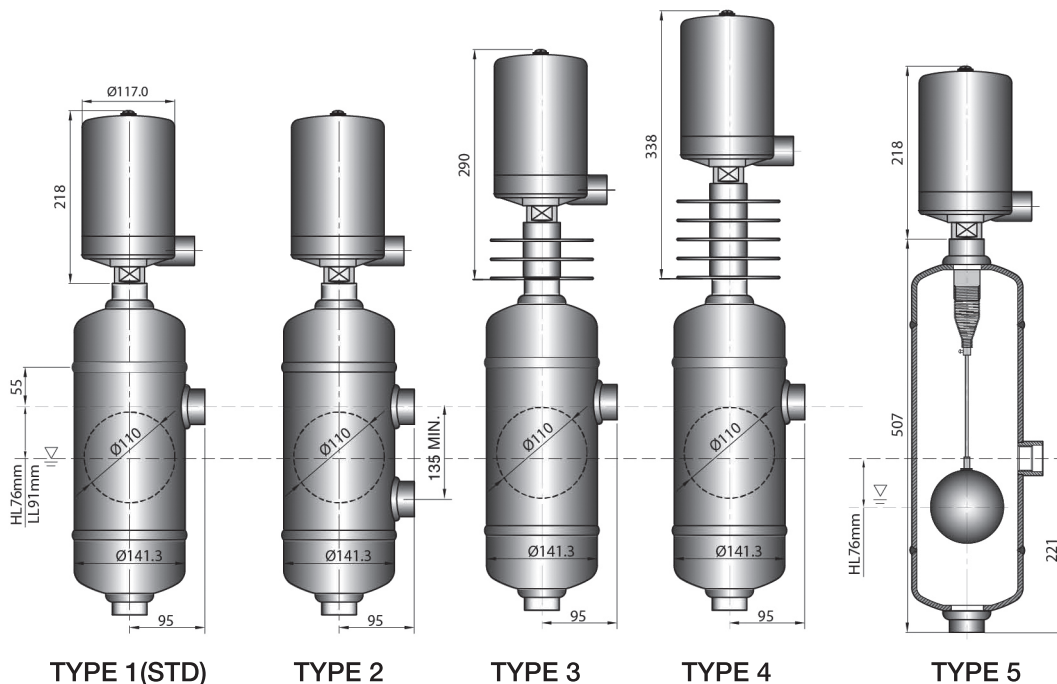

C to C of SMC-75B is fixed like the above length.

SMC-75F

5" Flange Type

Ordering Informations

Vertical Float Type Level Switch (5" Flange Type)

SMC - 75 F 1 A 1 A 1 A 1

CONDUIT CONNECTION

- 1 = PF 3/4" (Std.)
- 2 = PT 3/4"
- 3 = etc.

ENCLOSURE

- A = Weather Proof (Std., IP65, C.S Cover)
- B = Explosion Proof (Ex d IIC T6, IP67)
- C = ATEX (Ex d IIC T6)

PROCESS TEMP'(CONTACT RATING)

- 1 = Max.120° (10A 250V/AC/0.6A 125V DC)
- 2 = Max.230° (5A 250V AC/0.5A 125V DC)
- 3 = Max.400° (1A 250V AC/1A 30V DC)
- 4 = Max.230° (15A 250V AC/1A 125V DC)
- 5 = Max.400° (1A 115V AC/3A 28V DC)
(Hermetical Seal Type)
- 6 = Max.350° (5A 250V AC/0.5A 125V DC/Cooling Fin 3ea)
- 7 = Max.450° (1A 250V AC/1A 30V DC/Cooling Fin 3ea)
- 8 = Max.350° (15A 250V AC/1A 125V DC/Cooling Fin 3ea)
- 9 = Max.450° (1A 115V AC/3A 28V DC/Cooling Fin 3ea)
(Hermetical Seal Type)
- 10 = Max.450° (5A 250V AC/0.5A 125V DC/Cooling Fin 5ea)
- 11 = Max.550° (1A 250V AC/1A 30V DC/Cooling Fin 5ea)
- 12 = Max.450° (15A 250V AC/1A 125V DC/Cooling Fin 5ea)
- 13 = Max.550° (1A 115V AC/3A 28V DC/Cooling Fin 5ea)
(Hermetical Seal Type)

SNAP SWITCH ACTION (OUTPUT)

- A = 1 SPDT
- B = 1 DPDT

SETPOINT

- 1 = 180mm (Std., External Cage of Seojin Instech)
- 2 = 150 ~ 300mm (Tank Top Mounting Length = Min. 150mm)

MOUNTING TYPE

- A = 5" 150# ANSI RF Flange (Std.)
- B = 5" 300# ANSI RF Flange
- C = 5" 600# ANSI RF Flange
- D = 5" 900# ANSI RF Flange
- E = 5" 1500# ANSI RF Flange
- F = etc.

FLOAT MATERIAL

- 1 = 316 SS (Std.)
- 2 = Monel

MODEL SELECTION

- F = 5" Flange Type
(Max. Temp: 550°C, Max.
Pressure : 70 Bar)

When placing an order, selected ordering number should be indicated on the purchase order sheet.

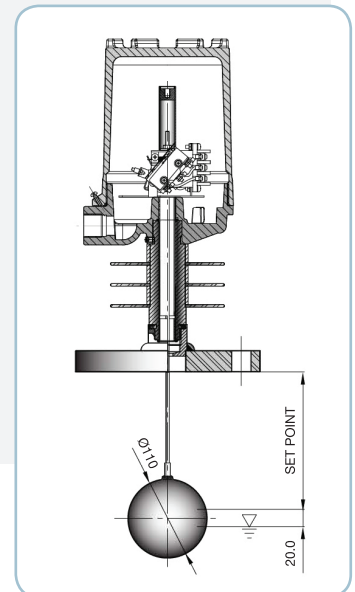
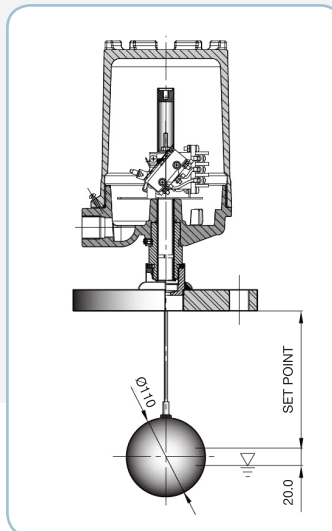

SMC-75CH

5" Chamber

Ordering Informations

Vertical Float Type Level Switch (Chamber)

SMC - 75CH A 1 A 1 A 1 D 1 A

TYPE OF CHAMBER

A = Side-Side
B = Side-Bottom
C = etc.

CHAMBER MATERIAL

1 = Carbon Steel (Std.)
2 = 304 SS
3 = 316 SS
4 = Carbon Steel with Teflon Coating
5 = etc.

PROCESS CONNECTION TYPE

A = Socket Welding Type (Std.)
B = Flange Type

PROCESS CONNECTION SIZE

1 = 1" (Std.)
2 = 3/4"
3 = 1-1/2"
4 = 2"
5 = etc.

TEST FOR WELDING

A = Hydro Test Only
B = PT Test + Hydro Test
C = etc.

PAINTING

1 = MFR Std. (Seojin Spec.)
2 = etc.

DRAIN PARTS (Side -Side Type Only)

A = PT 1/2" With Plug
B = PT 1/2" With Globe Valve
C = None
D = NPT 1/2" With Plug (Std.)
E = NPT 1/2" With Globe Valve
F = etc.

LENGTH (CTO C)

1 = 0 ~ 500mm
2 = 0 ~ 1,000mm
3 = 0 ~ 1,500mm
4 = 0 ~ 2,000mm
5 = etc.

TOP MOUNTING SIZE

A = 5" 150# ANSI RF Flange (Std.)
B = 5" 300# ANSI RF Flange
C = 5" 600# ANSI RF Flange
D = 5" 900# ANSI RF Flange
E = 5" 1500# ANSI RF Flange
F = etc.

■ When placing an order, selected ordering number should be indicated on the purchase order sheet.

SIDE-BOTTOM (SW)

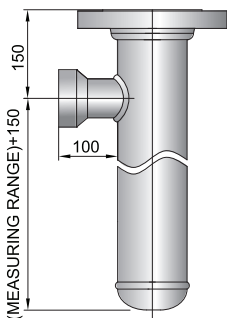

SIDE-BOTTOM (FLANGE)

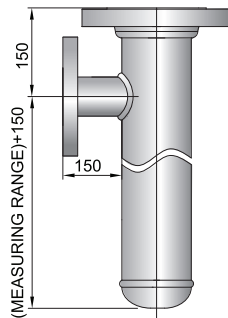

SIDE-SIDE (SW)

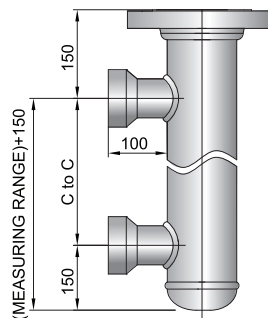

SIDE-SIDE (FLANGE)

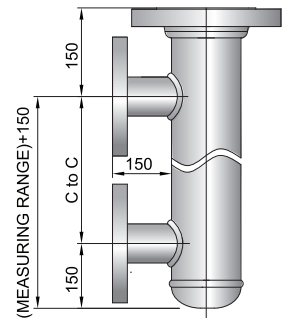

SMC-71

Flood Level Switch to Detect Leaks or Spills

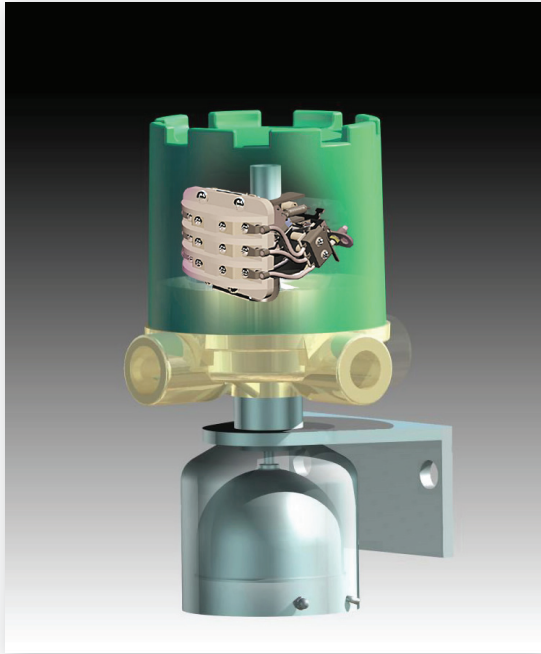

Features

- Can be used to detect leaks or spills from valves, vessels, and pipe lines in plant
- Designed to ASME B31.1
- Explosion-proof & Weather proof
- Unique and reliable; Snap acting switch mechanism
- Vibration resistant-eliminates spurious trips by special spring
- Multiple switches can be assembled in a unit for economical purpose.
- Weld procedures approved to KEPIC MQ and ASME IX
- Material certification to ASTM, ASME, JIS, KS Standards
- Qualified to IEEE 323-2003, and IEEE344-2004
- Applicable to hermetical seal type snap action switch

Approvals

KOSHA (The Korea Occupational Safety and Health Agency)- Approval Explosion proof Ex d IIC T6
(-20°C ≤ AMB ≤ 60°C)

General Area, Weather proof Type IP65

TÜV- Approval

CE Certificate

EN-61010-1-2001

KTL (Korea Testing Laboratory)- Tested to verify the requirements of Nuclear Power Plant Quality Standards.

IEC Pub. 60068 Basic Environmental Testing Procedures.

KEPIC Certificate of Registration

MN-125

ATEX

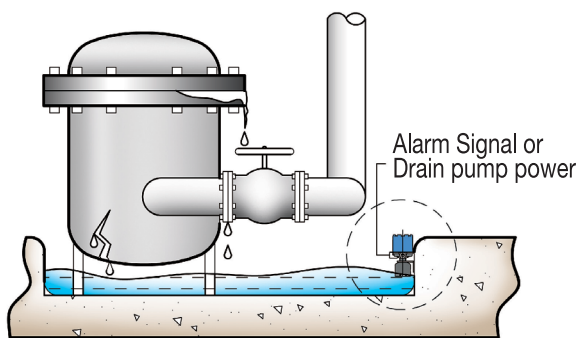

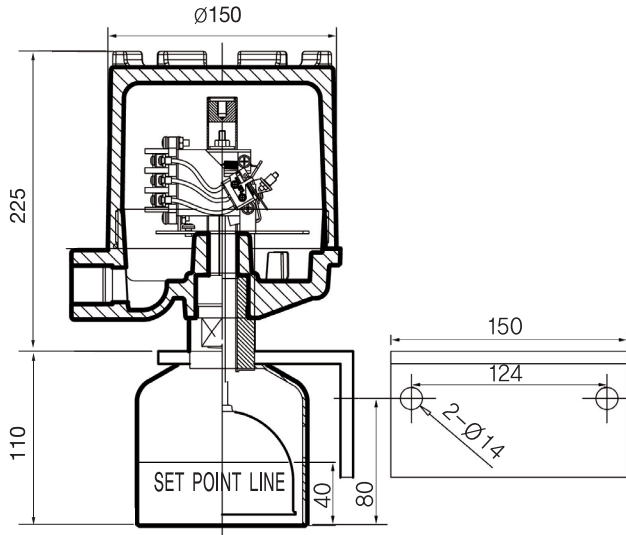

Quality Assurance

With over 35 year worldwide experience in the thermal power plant, nuclear power plant and petro-chemical industries, Seojin Instech is able to accommodate testing, surveying and documentation requirements as specified at the time of order. Inspection by customers or nominated inspection agencies can be arranged.

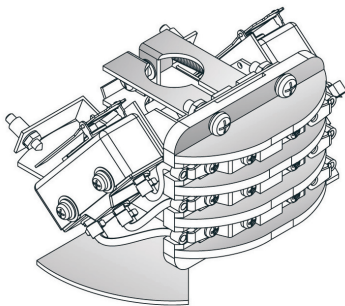

WIRING DIAGRAM

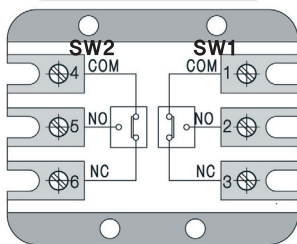

Technical Specifications

General Technical Specifications

Least Specific Gravity of Process: 0.6

Snap Acting Switch Assembly

- Switching type : Snap Acting Switch,
Dry Contact Type
- Contact(Output) : 1 SPDT, 1 DPDT
- Precision : $\pm 1\text{mm}$,
- Body Material : 304SS
- Terminal Material : Pure Ceramic

Chamber

- Made According to ASME B31.1, KEPIC MGE
- Material : C.S(Std.), 316SS, etc.

Float

- Material : 316SS(Std.)
- Float Specific Gravity: Minimum 0.4
- Size : OD 90mm,
- Maximum Temperature : 250°C

Switch Assembly

▶ Snap Acting Switch Assembly

Type (Model)	SM1S	SM1D	SM3S	SM3D	SM4S	SM4D
Action	SPDT / DPDT		SPDT / DPDT		SPDT / DPDT	
Operating Temperature Range	- 25 ~ 80°C		- 54 ~ 204°C		- 65 ~ 260°C	
Voltage & Current	250V AC 10A		250V AC 15A		115V AC 1A	
	125V DC 0.6A		125V DC 1A		28V DC 3A	
Remark					Hermetical Seal	

Ordering Informations

■ Flood Level Switch to Detect Leaks or Spills

SMC-71 A 1 A 1 A 1

PAINTING

1 = MFR Std.(Seojin Spec.)
2 = etc.

CONDUIT CONNECTION

A = PF 3/4" (Std.)
B = PF 1"
C = etc.

OPERATING TEMP' (CONTACT RATING)

1 = -25 ~ 80°C(10A 250V AC / 0.6A 125V DC)
2 = -54 ~ 204°C(15A 250V AC / 1A 125V DC)
3 = -65 ~ 260°C(1A 115V AC / 3A 2

SNAP ACTION SWITCH (OUTPUT)

A = 1 SPDT
B = 1 DPDT

FLOAT MATERIAL

1 = 316SS
2 = etc.

WETPART MATERIAL

A = Carbon Steel
B = 316SS
C = etc.

■ When placing an order, selected ordering number should be indicated on the purchase order sheet.



12, Sagimakgol-ro 148beon-gil, Jungwon-gu,
Seongnam-si, Gyeonggi-do, 462-807, Korea
☎ +82-31-627-9000 📠 +82-31-624-5345
<http://www.seojin.biz>

Printed by Daoom. 2010. 04 98-CG-006-1. Rev: 0

■ Specifications subject to change without notice